

# GX 12/35 EVO AGM

## FULLY FEATURED COMPACT STACKER



This compact, powerful and robust stacker is the ideal solution for working in confined spaces.

The reduced width (800 mm), the lateral driving system and the wide mast positioning allow great manoeuvrability, stability and visibility.

Built-in battery charger with integrated cable and plug make it a plug and play unit!

### GX EVO AGM

The EVO version is equipped with powerful AGM deep cycle batteries that allow long endurance and large number of charging cycles. The ergonomic technopolymer tiller offers a comfortable grip. A specific electronic control enables lifting the forks with a proportional usage.



### MANOEUVRABILITY

The overall width has the same size than the EuroPallet (800mm) allow the unit to work in narrow spaces and corridors, increase maneuverability and reducing the turning radius.

The combination of the lateral drive, the wide mast and the low carter offer outstanding visibility.



### TILLER EVOLUTION

Fully integrated ergonomic technopolymer tiller system including finger tip throttle and proportional fork controls, safety pushbutton, horn, turtle button, hourmeter, battery status indicator as standard equipment.



## TURTLE MODE SWITCH

Offered as standard, this function enables operating the truck in confined spaces: it allows the unit to travel with the tiller in upright position.

This function is activated by pressing the turtle button on the tiller and rotating the drive control throttle. The truck travels at limited speed.

Release the button to disable this function.



## COVER

Strong ABS carter/cover with storage compartments on top, easily removable to speed up maintenance operations. The bottom access opening allows an immediate disassembly of motor wheel, portal and tiller without lifting the machine. Schuko plug with spiral cable for an easy battery charging.



## BATTERY PACK AGM

A separate compartment is the housing of AGM deep cycle batteries. Such batteries are powerful (110Ah), allow 3 hours endurance and don't need maintenance. GEL batteries available on demand.



## GEL (OPTIONAL)

GEL batteries available on demand.



## Descriere

1.1 Producător			PR INDUSTRIAL
1.3 Comandă			ELECTRICĂ
1.4 Poziție operare			Pedestru
1.5 Capacitate maximă	Q	Kg	1200
1.6 Distanța la centrul de aplicare al sarcinii	c	mm	600
1.8 Sarcina de la osie la capătul furcilor	x	mm	780
1.9 Ampatament	y	mm	1234

## Greutăți

2.1 Greutate de operare (acumulator inclus)		Kg	618
2.2 Sarcină osie, încărcare pe spate		Kg	1187
2.2 Sarcină osie, încărcare pe față		Kg	631
2.3 Sarcină osie, liber față		Kg	456
2.3 Sarcină osie, liber spate		Kg	162

## Cauciucuri/Șasiuri

3.1 Cauciucuri: roți direcție			CAUCIUC
3.1 Cauciucuri: roți stabilizatoare - Față			POLY.C.
3.1 Cauciucuri: transportoare cu role			POLY.C.
3.2 Mărime cauciuc: roți direcție - Lățime		mm	76
3.2 Mărime cauciuc: roți direcție - Diametru		mm	250
3.3 Mărime cauciuc: transportoare cu role - Diametru		mm	82
3.3 Mărime cauciuc: transportoare cu role - Lățime		mm	70
3.4 Mărime cauciuc: roți stabilizatoare față - Diametru		mm	100
3.4 Mărime cauciuc: roți stabilizatoare față - Lățime		mm	38
3.5 Dimensiune cauciuc: roti spate		nr	2
3.5 Dimensiune cauciuc: roti fata		nr	1x+1
3.6 Ecartament, față	b10	mm	565
3.7 Ecartament, spate	b11	mm	410

**Dimensiuni**

4.2 Înălțime, catarg coborât	h1 mm	2250
4.3 Înălțime de lucru fără încărcătură	h2 mm	80
4.4 Înălțime stivuitor	h3 mm	3410
4.5 Înălțime, catarg ridicat	h4 mm	3916
4.9 Height of tiller in drive position min	h14 mm	960
4.9 Înălțime manetă în poziția de deplasare, max	h14 mm	1330
4.15 Înălțime, coborât	h13 mm	90
4.19 Lungime globală	l1 mm	1760
4.20 Distanța până la suprafața frontală a furcilor	l2 mm	609
4.21 Lățime globală	b1 mm	800
4.22 Dimensiuni furcă - grosime	s mm	70
4.22 Dimensiuni furcă - Lățime	e mm	150
4.22 Dimensiuni furcă - Lungime	l mm	1150
4.24 Lățime furcă transpalet	b3 mm	650
4.25 Distanța între furci	b5 mm	560
4.32 Gardă la sol și mijloc ampatament	m2 mm	20
4.34 Lățime culoar	Ast mm	2210
4.35 Rază de virare	Wa mm	1430

**Performante**

5.1 Viteză de deplasare cu incarcare	Km/h	4.7
5.1 Viteză de deplasare fără incarcare	Km/h	5.2
5.10 Frână de serviciu	REVERSE CURRENT BRAKING	

**Motoare electrice**

6.6 Consum de energie în ciclu VDI	kWh/h	0.9
8.4 Nivel sonor la nivelul urechii șoferului	dB(A)	62

**Elevare reziduală capacitate**

Înălțimea de elevare (H3) 2500 mm	Kg	1200
Înălțimea de elevare (H3) 2900 mm	Kg	800
Înălțimea de elevare (H3) 3500 mm	Kg	600

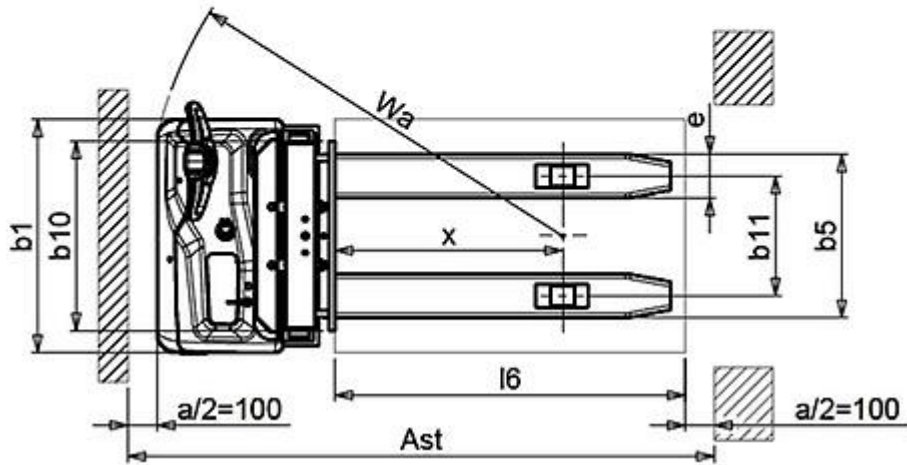
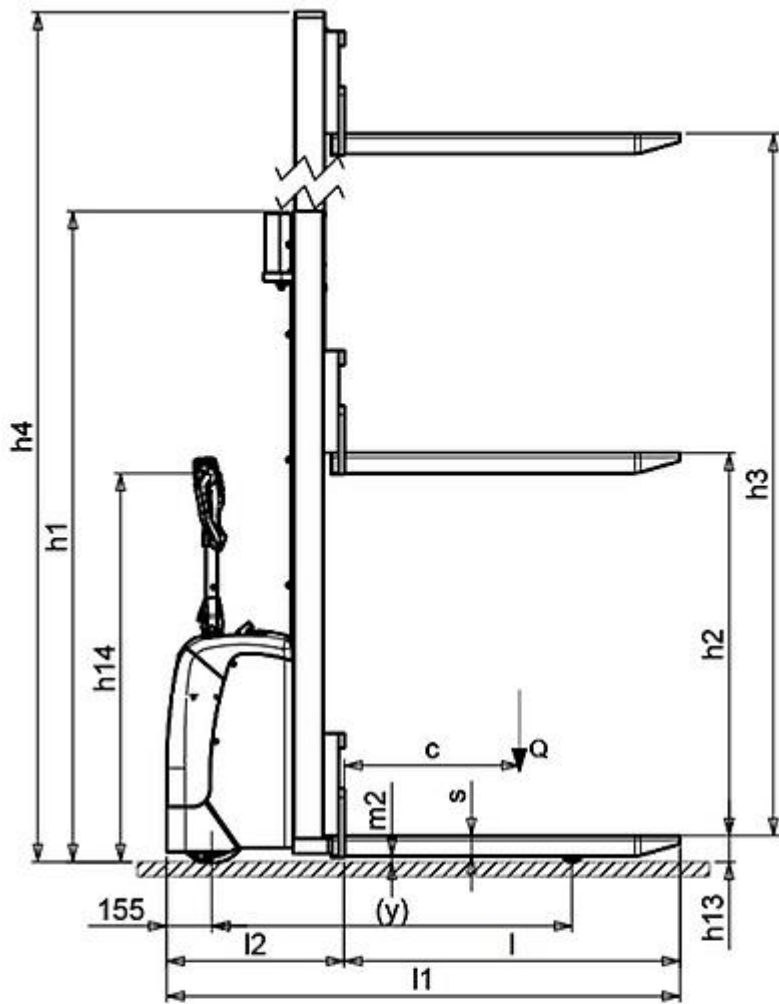

The information is aligned with the Data file at the time of download. Printed on 24/02/2020 (ID 10063)

©2019 | PR INDUSTRIAL s.r.l. | All rights reserved | Image shown may not reflect actual package. Specifications subject to change without notice

